



UNIVERSITÀ DEGLI STUDI DI NAPOLI
FEDERICO II

iteePhD
information technology
electrical engineering



Tessitore Salvatore

Innovative measurement solutions based on 4.0 technologies for electricity transmission networks

Tutor:
Prof. Angrisani Leopoldo

Co-Tutors:
Prof.ssa Liccardo Annalisa
Ing. Giannuzzi Giorgio Maria (Terna spa)

Cycle: XXXV

Year: First

My background

- MSc degree: Electrical Engineering
- Research group: Electrical and Electronic Measurements
- PhD start date: 01/11/2019
- Scholarship type: No Scholarship
- Partner company: Terna S.p.a

Research activity: Overview

- My research area is the Measurement of Power System Stability

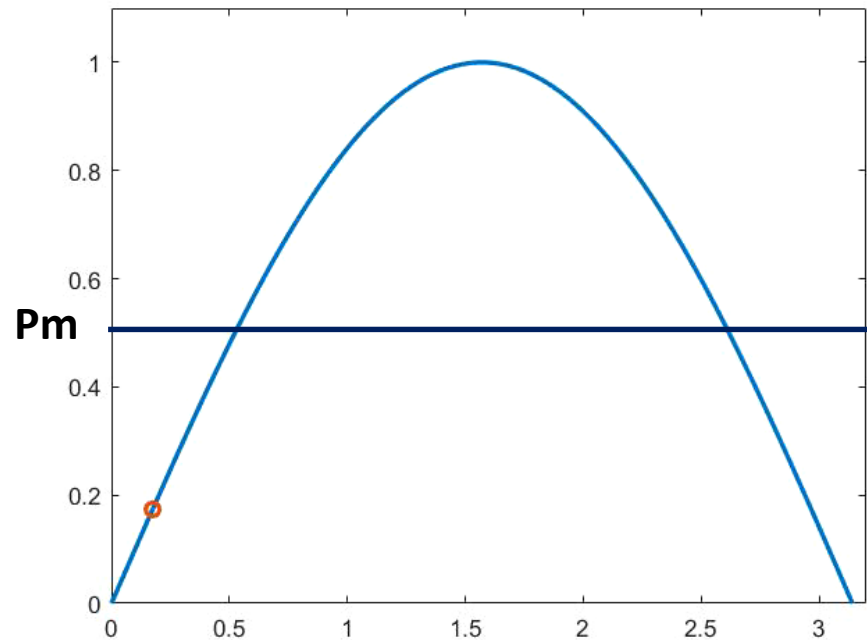
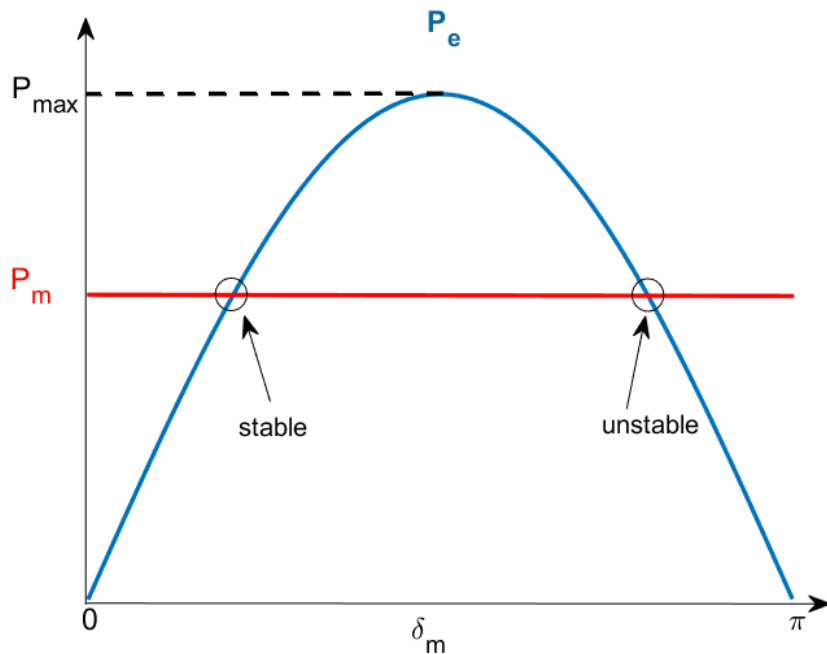

Research activity: Problem statement

- The system frequency varies linearly with the speed of the generators connected to the grid

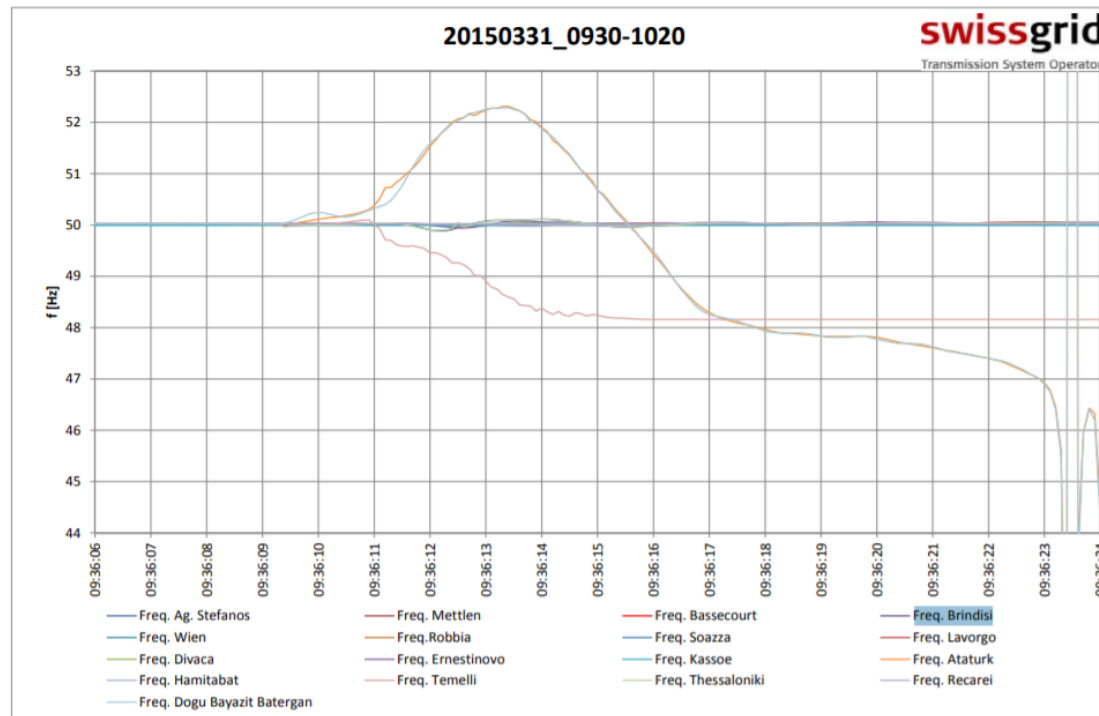

Research activity: Objectives

Particle Swarm Optimization method

1. Heuristic method
2. Low computational time
3. Low accuracy

Hilbert Transform method

1. Based on signal tracks
2. High computational time
3. High accuracy

Products

1. *A PSO-MMA method for the parameters estimation of inter-area oscillations in electrical grids*
2. *A novel PSO-CWA algorithm for the estimation of inter-area oscillation parameter*
3. *Parameter Identification of Interarea Oscillations in Electrical Power Systems via an Improved Hilbert Transform Method*

Research activity: Future tasks

The implementation of a benchmark to reproduce the real network system used by the Italian TSO (Transmission System Operator) in order to test the algorithms implemented according to the methods found in the literature

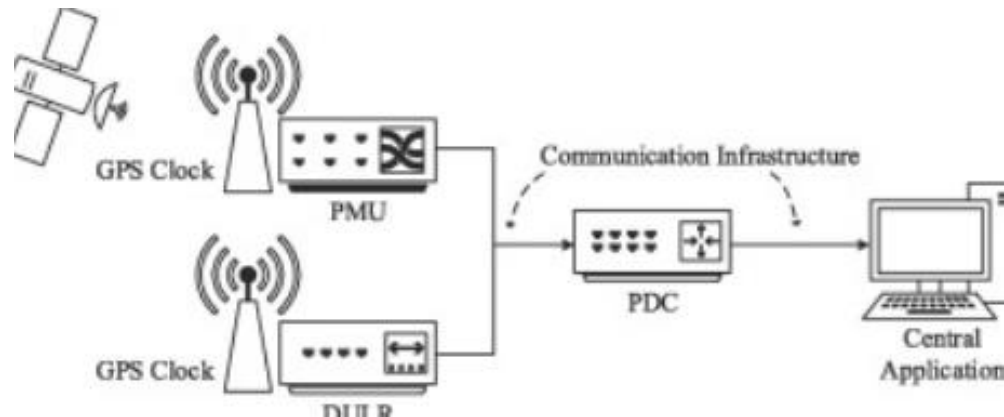

Summary of study activities

	Courses	Seminars	Research	Tutorship	Total
Bimonth 1	0	0	10	0	10
Bimonth 2	9	0	4	0	13
Bimonth 3	0	0.6	5	0	5.6
Bimonth 4	5	5.3	6	0	16.3
Bimonth 5	12	0	5	0	17
Bimonth 6	3	0	5	0	8
Total	29	5.9	35	0	69.9
Expected	20 - 40	5 - 10	10 - 35	0 - 1.6	



Thank you for your attention